

D(LR20)
General Features

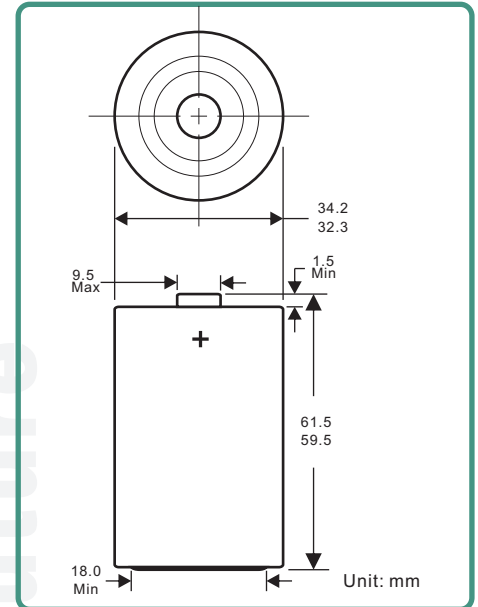

▶ Designation	IEC-LR20 JIS-AM1 ANSI-13A Others-D,E95,MN1300
▶ Chemical system	Alkaline-Manganese Dioxide ※No added Mercury and Cadmium
▶ Nominal Voltage	1.5V
▶ Weight	Approx.136g
▶ Terminal	Flat
▶ Storage Temperature Range	-20°C~35°C
▶ Operating Temperature Range	-20°C~54°C
▶ Jacket	Foil Jacket
▶ Shelf Life	4 years(80% of rated capacity)
▶ Standards	IEC60086 2006/66/EC



Electrical Characteristics

CONDITION	OCV (V)	CCV (V)	SCC (A)
Fresh Battery	1.62	1.50	14
After 3 mths	1.60	1.45	12
After 12 mths	1.60	1.45	11

Test Conditions Load resistance:2.2Ω±0.5%; Measuring time:0.2S; Temperature:20±2°C

Discharge Characteristics: (20±2°C, RH:45%~75%)

Standard	Discharge Condition			Average Discharge Time		
	Discharge Load	Discharge Time	E.P.V.	Fresh Battery	After 12mths	After 36mths
IEC	10Ω	4h/d	0.9V	100h	95.0h	87.0h
IEC	3.9Ω	1h/d	0.9V	38.0h	36.0h	34.0h
IEC	2.2Ω	4m/h,8h/d	0.9V	24.0h	22.0h	20.0h
IEC	2.2Ω	1h/d	0.8V	19.5h	18.2h	17.0h
REF	2.2Ω	24h/d	0.9V	18.0h	17.0h	16.0h

Constant Resistance Performance

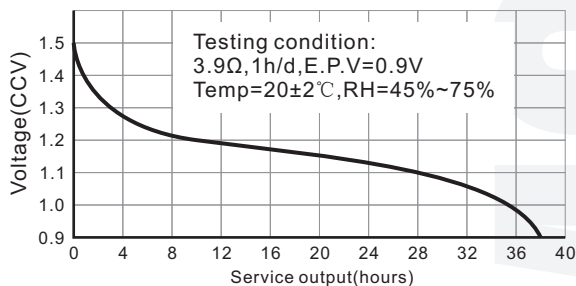

Constant Resistance Performance

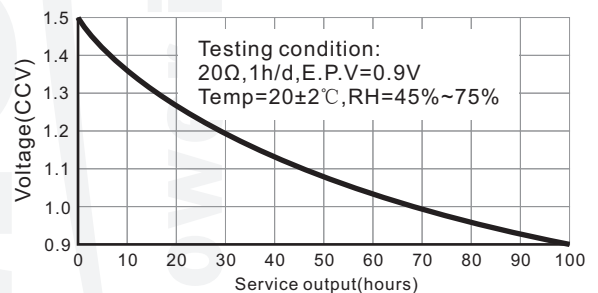

Constant Resistance Performance

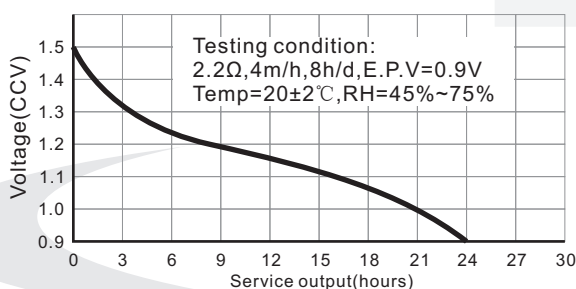

Constant Resistance Performance

